

Zintra Acoustic Blades

Installation Instructions

FINISHED ASSEMBLY

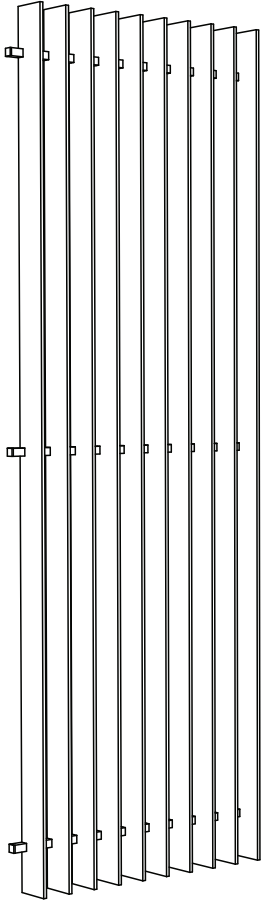

* Design shown as an example only Instructions apply to all Blade designs.

PARTS LIST



CROSSRUNNERS



END CAP



BLADES - as per specified design

Zintra Acoustic Blades Installation Instructions

STEP 1

Secure Blade crossrunner to wall in the suitable location for your site.

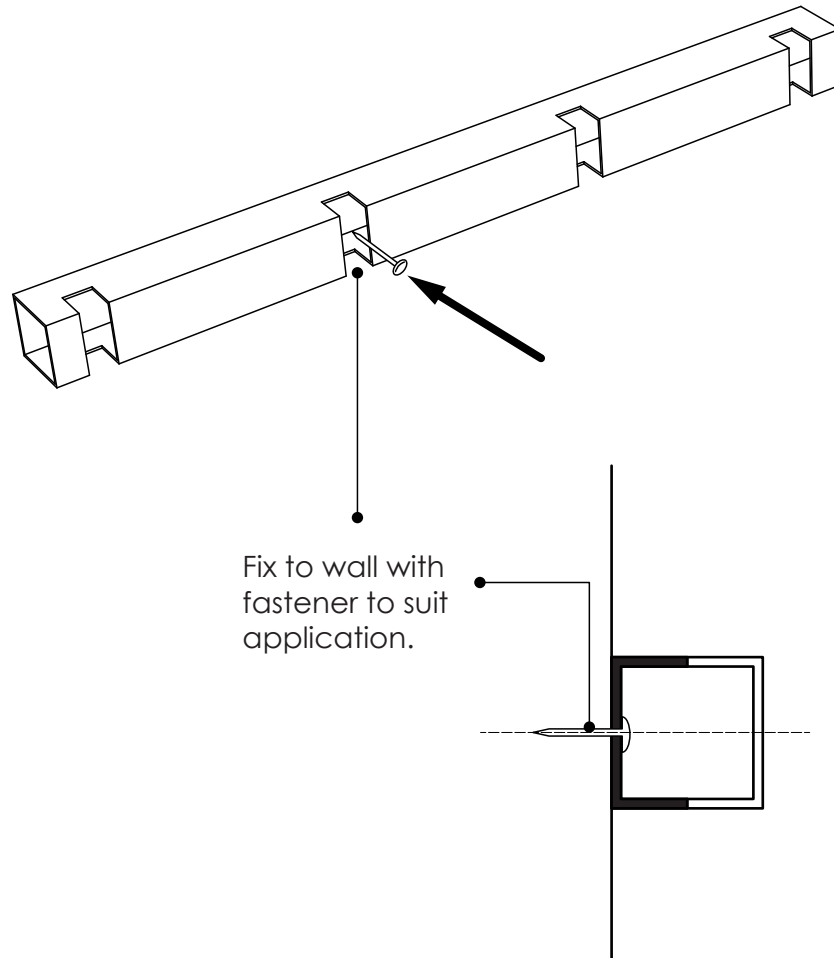

STEP 2

Fix crossrunners in parallel - Fit end blades temporarily to accurately position crossrunners.

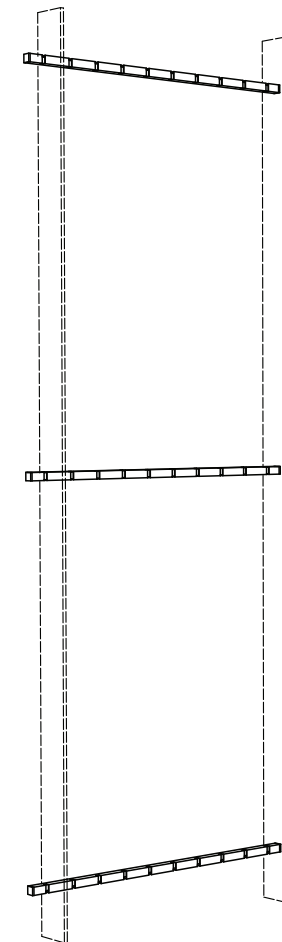

Zintra Acoustic Blades

Installation Instructions

STEP 3

For the most secure installation, apply silicone (not supplied) to inside of extrusion prior to fixing off blades. Ensure even application.

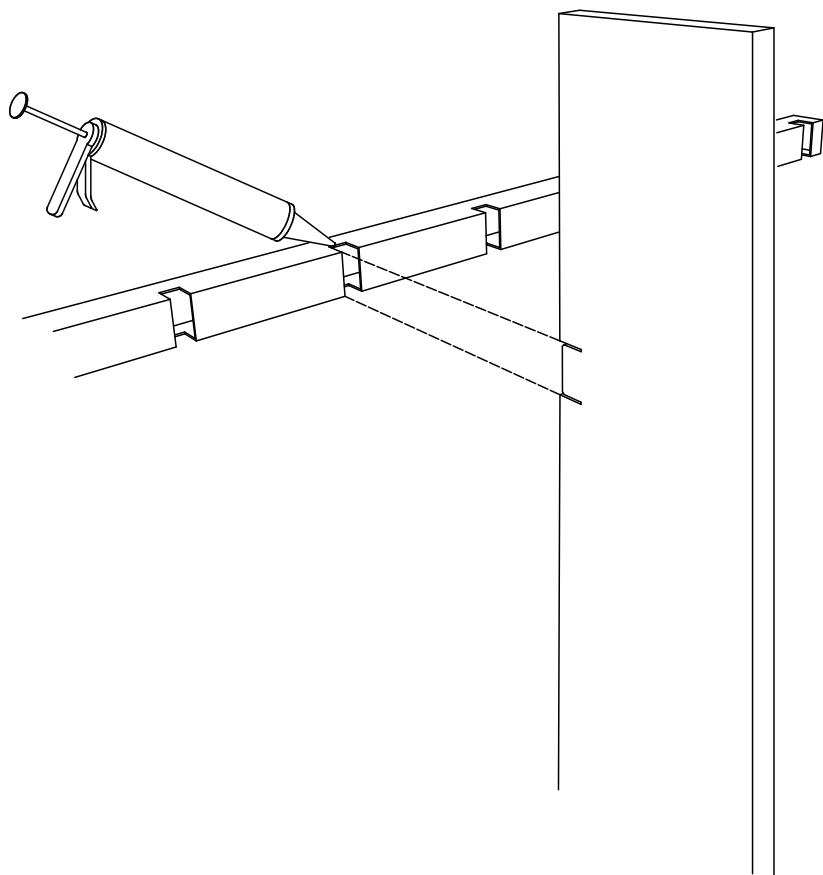

STEP 4

Fix Blades off starting from the center. Wipe away excess silicone with a damp cloth. Note: Layout the blades for your system prior to installing to assure you have them in the correct order for the desired pattern.

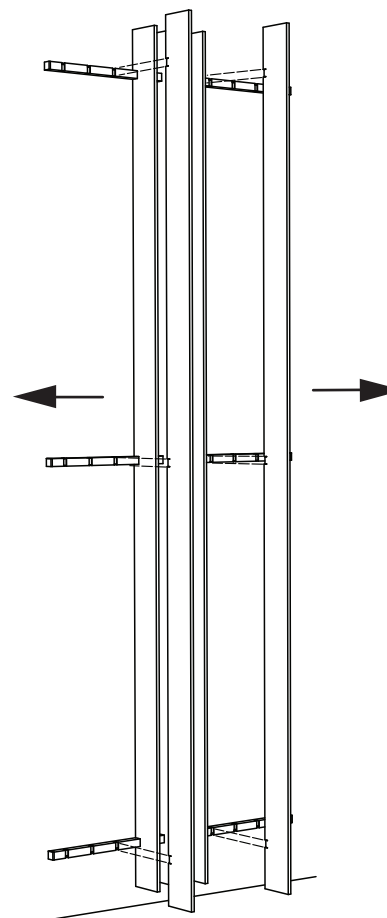

Zintra Acoustic Blades

Installation Instructions

STEP 5

Fix end caps to extrusion.

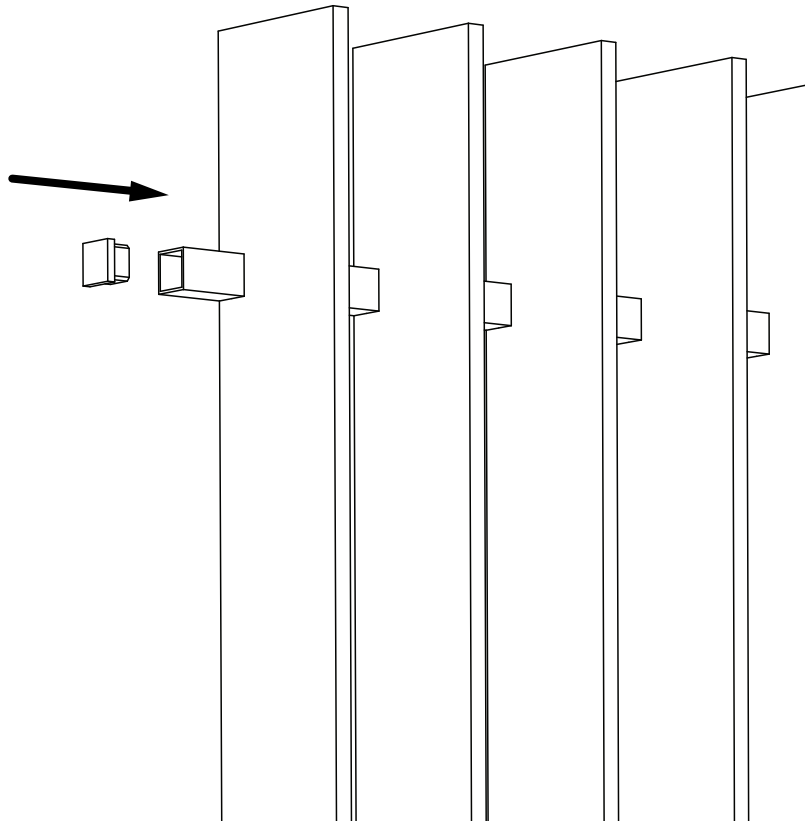

STEP 6

Allow silicone to cure as per manufacturer's instructions.

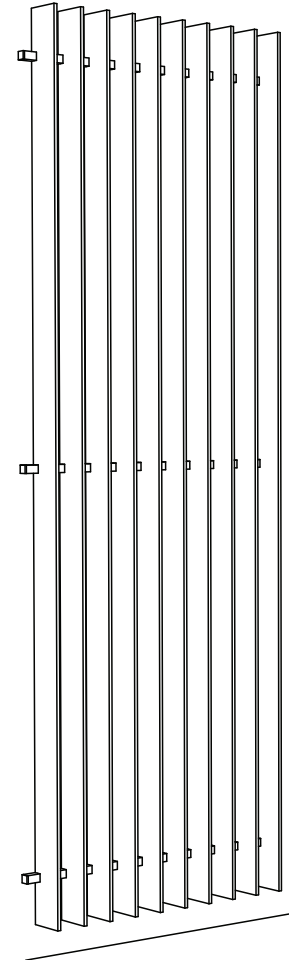

*image for reference only -refer to drawings for specified design isometric views